

PERMANENT ELECTROMAGNETIC CHUCKS

Model EP-Q PERMANENT ELECTROMAGNETIC CHUCK FOR MILLING

A Line-up of Products Selectable According to Machining Methods and Workpieces.

Electricity is required only when mounting and dismantling workpieces. Workpieces can be held firmly in the event of power failure.

Usable in wet machining operations.

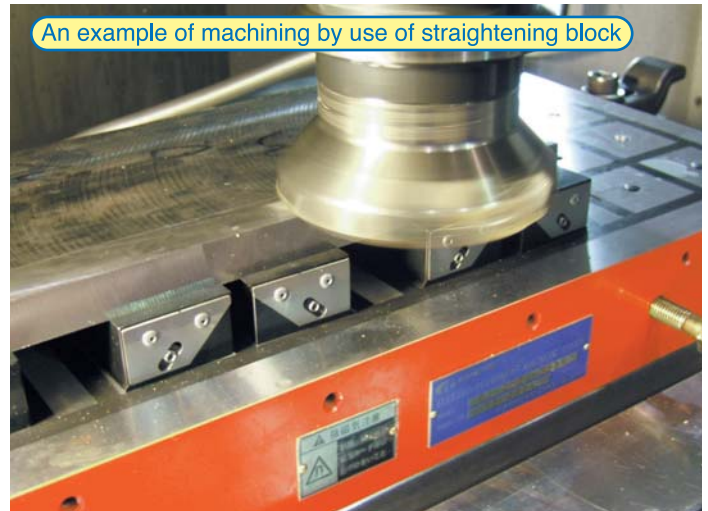

[Application]

Suitable for securing workpieces during cutting on milling machines and machining centers.

[Features]

- Can be used in wet machining operations.
 - Less accuracy change and highly robust construction.
 - Magnetization and demagnetization in a very short time.
 - Tapped holes on the attractive face can be used to install various blocks to hold workpieces by various methods according to machining operations.
 - The chuck is very thin, 70 mm in height, and light weight.
 - Straightening blocks are also available that are mounted on the chuck work face to hold workpieces by an induction field. These optional products are very useful for such workpieces of irregular attractive faces that for example have steps and distortion and for machining the bottom and side faces of workpieces.
 - The detachable feeder connector is optionally available for pallet change.
- <When ordering>
- Sizes other than the standard sizes listed in the right-side table are also available.
 - The maximum one-piece size is W1300 x L1500 mm. For larger sizes, chucks are to be connected.
 - When workpieces are hardened steels or special steels, they may be difficult to dismount due to strong residual magnetism.

Model designation

CHUCK : EP-QN50-3060

Chuck size: 50, Pole size: 60

□ Normal (Ribs arranged between poles) Pole size (□50 or □70)
 □ Hard (Poles arranged densely)

A guide for selection

General milling operations	Good attractive condition such as plate machining.	→ QN
Planmiller, horizontal M/C, use of straightening blocks, etc.	Poor attractive conditions such as heavy duty cutting	→ QH

Selection of pole size □50 or □70

- The □70 size is superior in the absolute holding power and gap characteristic.
- The □50 size is recommended for relatively small and thin workpieces. (The plate thickness of magnetic saturation is 20~25 mm for □50 and 30~35 mm for □70.)

Relation between chuck models and holding power

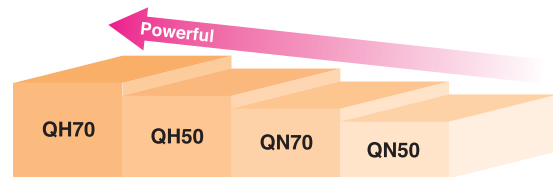

Holding power

□50 produces the maximum holding power of 2.94 kN (300 kgf) or over and □70 produces 5.88 kN (600 kgf) or over per pole.

<An example of calculation>

Maximum holding power on entire attractive face of EP-QH50-4080
 $2.94\text{kN} \times 60 \text{ (number of poles)} = 176.4\text{kN} \{18000\text{kgf}\}$

EP-Q type holding power characteristic

- Relation between workpiece thickness and holding power. Test piece held by 4 poles.

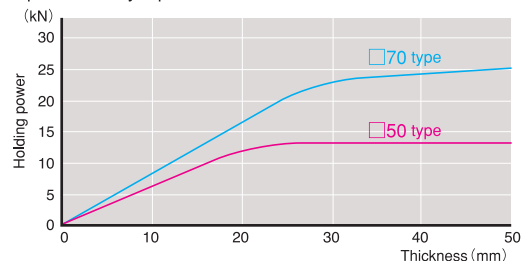

- Relation between gaps and holding power using □300 test piece.

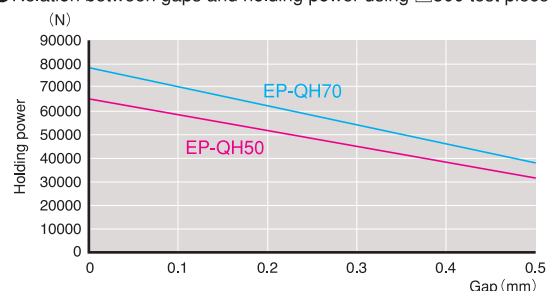

※ The holding power of Model EP-QN is 60% to 70% of Model QH.

ELECTROMAGNETIC CHUCK CONTROLLERS MAGNETIC CHUCKS PERMANENT ELECTROMAGNETIC CHUCKS BLOCKS FOR M/C VACUUM CHUCKS PROMELTA SYSTEM SINE BAR CHUCKS INJECTION MOLDING MACHINE MOLD FIXTURE WORKING TOOLS MAGNETIC BLOCKS MEASURING TOOL HOLDERS MEASURING TOOLS

An example of special fabrication



EP-QN50-80130

Chuck controller required additionally

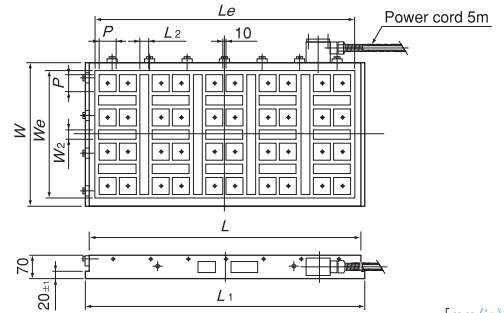

Standard Size Model	Chuck Work Face		Pole Dimensions				Mounting Face			Attractive Face Thread Hole		Mass	Applicable Chuck Master	
	W	L	W _e	L _e	No. of Poles	P	W ₂	L ₂	L ₁	N	M			
EP-QN50	3060	300 (11.8)	610 (24.0)	252 (9.92)	570 (22.4)	24	50 (1.96)	18 (0.70)	14 (0.55)	630 (24.8)	24 (0.94)	8 (0.31)	90kg/198 lb	EPS-P2100A
	4080	420 (16.5)	800 (31.5)	372 (14.6)	760 (29.9)	40		28 (1.10)	25 (0.98)	820 (32.2)	40 (1.57)		160kg/352 lb	EPS-P2100A-2
	50100	500 (19.6)	960 (37.8)	432 (17.0)	917 (36.1)	60		18 (0.70)		980 (38.5)	60 (2.36)		230kg/507 lb	EPS-P2100A-3
	60100	600 (23.6)		552 (21.7)		72		24 (0.94)	72 (2.83)	280kg/617 lb				
EP-QN70	4080	390 (15.3)	800 (31.5)	332 (13.0)	760 (29.9)	24	70 (2.75)	24 (0.94)	820 (32.2)	24 (0.94)	10 (0.39)	150kg/330 lb	EPS-P2100A	
	50100	500 (19.6)	1000 (39.3)	452 (17.8)	960 (37.8)	40		28 (1.10)	1020 (40.1)	40 (1.57)		240kg/529 lb	EPS-P2100A-2	
	60100	620 (24.4)		572 (22.5)		50		25 (0.98)	60 (2.36)	300kg/661 lb		EPS-P2100A-3		

An example of special fabrication



EP-QH70-4090

Chuck controller required additionally

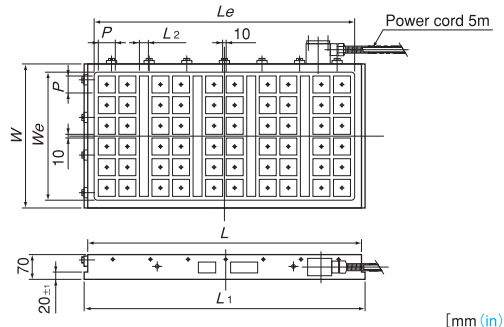

Standard Size Model	Chuck Work Face		Pole Dimensions				Mounting Face			Attractive Face Thread Hole		Mass	Applicable Chuck Master
	W	L	W _e	L _e	No. of Poles	P	L ₂	L ₁	N	M			
EP-QH50	3060	300 (11.8)	610 (24.0)	252 (9.92)	570 (22.4)	32	50 (1.96)	14 (0.55)	630 (24.8)	32 (1.26)	8 (0.31)	90kg/198 lb	EPS-P2100A-2
	4080	420 (16.5)	800 (31.5)	372 (14.6)	760 (29.9)	60		25 (0.98)	820 (32.2)	60 (2.36)		160kg/352 lb	EPS-P2100A-3
	50100	500 (19.6)	960 (37.8)	432 (17.0)	917 (36.1)	84			980 (38.5)	108 (4.25)		230kg/507 lb	EPS-P2100A-6
	60100	600 (23.6)		552 (21.7)		108		70 (2.75)	108 (4.25)	280kg/617 lb			
EP-QH70	3060	300 (11.8)	600 (23.6)	252 (9.92)	562 (22.1)	18	70 (2.75)	23 (0.90)	620 (24.4)	18 (0.70)	10 (0.39)	86kg/189 lb	EPS-P2100A
	4080	390 (15.3)	800 (31.5)	332 (13.0)	760 (29.9)	32		24 (0.94)	820 (32.2)	32 (1.26)		150kg/330 lb	EPS-P2100A-2
	50100	470 (18.5)	1000 (39.3)	412 (16.2)	960 (37.8)	50		25 (0.98)	1020 (40.1)	50 (1.96)		220kg/485 lb	EPS-P2100A-3
	60100	620 (24.4)		572 (22.5)		70		70 (2.75)	300kg/661 lb	EPS-P2100A-5			

※Turning the permanent electromagnetic chucks on and off must be limited to once per several minutes. If on/off operations are repeated frequently, the chucks may be damaged by overheat.

EP Chuck Master



EPS-P2100A

Model designation

CHUCK MASTER : EPS-P2100A-2, 3, 4, 5, 6

Switching over of output

Model	Dimensions (W×H×D)	Operation Box (W×H×D)	Power Source	Output	Output Switchover	Magnetizing Time (approx.)	Demagnetizing Time (approx.)	Breaker Capacity (Ref.)
EPS-P2100A	400 (15.7)×450 (17.7)×200 (7.87)	100 (3.93)×120 (4.72)×70 (2.75) Cord 5m (196)	200 VAC 50/60Hz 1 φ	90 VDC Average: 100A (Max.: 300A)	No switchover	1s	30A	
EPS-P2100A-2	450 (17.7)×450 (17.7)×200 (7.87)				2	3s		
EPS-P2100A-3	550 (21.6)×450 (17.7)×200 (7.87)				3	4s		
EPS-P2100A-4					4	7s		
EPS-P2100A-5	600 (23.6)×750 (29.5)×250 (9.84)				5	9s		
EPS-P2100A-6					6	11s		60A

Options

①Straightening blocks for □50 and □70

Model		Type
□50	□70	Fixed
KT-Q50	KT-Q70	
KT-Q50M	KT-Q70M	Movable



KT-Q50M

②Separately installed feeder

Recommended for pallet change spec.

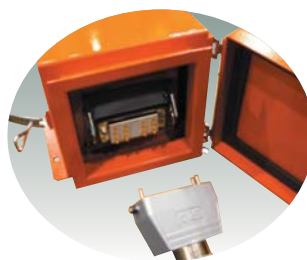

Model of special specification

Model with T-slots available



EP-QX50-S

※For more information, please contact us.

ELECTROMAGNETIC CHUCKS
CHUCK CONTROLLERS
PERMANENT MAGNETIC CHUCKS
ELECTROMAGNETIC CHUCKS
BLOCKS FOR MC
VACUUM CHUCKS
PROMELTA SYSTEM
SINE BAR CHUCKS
INJECTION MOLDING MACHINE MOLD FIXTURE
WORKING TOOLS
MAGNETIC BLOCKS
MEASURING TOOLS
TOOL HOLDERS

PERMANENT ELECTROMAGNETIC CHUCKS

Model EPT STANDARD TYPE



EPT-3060D

Chuck controller required additionally



[Application]

Most suitable for highly accurate grinding such as precision grinding and slicing.

[Features]

- Electricity is applied momentarily only to control the magnetomotive force when mounting and dismounting workpieces, minimizing heat generated internally to ensure high precision machining operations.
- Electricity needs not be applied continuously even when holding workpieces, helping reduce running costs.
- The holding power is maintained by the permanent magnet in the event of power failure, improving safety.

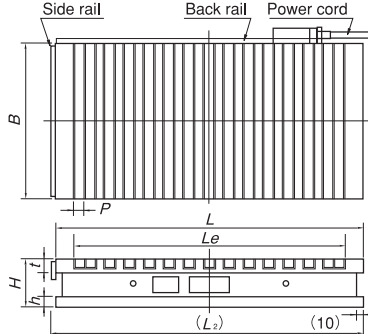

Note: The dimension L2 has not been machined together with the dimension L and some variation exists.

An example of large size fabrication

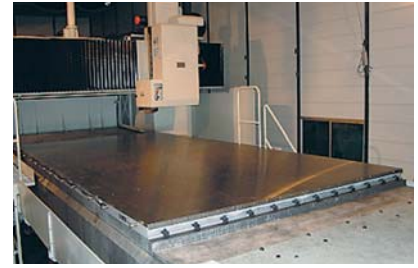

[mm (in)]

Model	Nominal Dimensions	Top Plate			Pole Pitch	Bottom Plate		Height	Voltage	Current	Power Cord	Mass	Electro Chuck Master	
		B ₁	L	Le		L ₂	h							
EPT- 1530D	150 (5.90) × 300 (11.8)	150 (5.90)	300 (11.8)	240 (9.44)	20.5 (0.80)	14 (2+12) 0.55 (0.07+0.47)	300 (11.8)	20 (0.78)	80 (3.15)	180 VDC ※1	2m (78.7)	24kg/ 52 lb	EPH-LW205A EPS-W215B	
EPT- 1535D	350 (13.7)		296 (11.6)	350 (13.7)			31kg/ 68 lb							
EPT- 1545D	450 (17.7)		380 (14.9)	450 (17.7)			40kg/ 88 lb							
EPT- 2050D	500 (19.6)		436 (17.1)	500 (19.6)			66kg/145 lb							
EPT- 2060D	200 (7.87) × 600 (23.6)	200 (7.87)	600 (23.6)	548 (21.5)	25.0 (0.98)	19.5 (2.5+17) 0.76 (0.09+0.66)	600 (23.6)	25 (0.98)	100 (3.93)		3m (118)	70kg/154 lb		
EPT- 3060D	300 (11.8) × 600 (23.6)	300 (11.8)	600 (23.6)	529 (20.8)			800 (31.5)					211kg/465 lb		
EPT- 4080D	400 (15.7) × 800 (31.5)	400 (15.7)	800 (31.5)	724 (28.5)			800 (31.5)					275kg/606 lb		
EPT-40100D	400 (15.7) × 1000 (39.3)	400 (15.7)	1000 (39.3)	919 (36.1)			1000 (39.3)					330kg/727 lb		
EPT-50100D	500 (19.6) × 1000 (39.3)	500 (19.6)	1000 (39.3)	919 (36.1)							5m (196)	330kg/727 lb		EPH-LW210A EPS-W215B

※1...A 90V model is also available. Please contact us. ※The chuck controller and clamp parts are not included. The KANETEC chucks work best when a KANETEC chuck controller is used.
※Turning the permanent electromagnetic chucks on and off must be limited to once per several minutes. If on/off operations are repeated frequently, the chucks may be damaged by overheating.

Model EPH-LW EP CHUCK MASTER*

Low magnetic force control function



EPH-LW205A

[Application]

The use of the low magnetic force control function enables straightening operations as with electromagnetic chucks.

The use of the low magnetic force control function facilitates positioning of workpieces. (The low magnetic force control requires electricity to be supplied continuously. When used under low magnetic force control for long hours, accuracy change due to heat generated in the permanent electromagnetic chuck may slightly affect the machining accuracy.)

[Features]

These Chuck Masters enable it to control the low magnetic force (weak holding power), which is difficult with permanent electromagnetic chucks. When a conventional permanent electromagnetic chuck is used, it is necessary to turn it off once and after lowering the magnetizing voltage, turn it on again in order to set a low magnetic force for straightening grinding operations. These Chuck Masters have a control function by which the power can be applied continuously only in the low output region, which makes it possible to finely and continuously adjust the low magnetic force region as with electromagnetic chucks. They offer a capability of straightening grinding with permanent electromagnetic chucks. Workpieces can also be positioned smoothly with the low magnetic force control.

<EPH-LW205A>

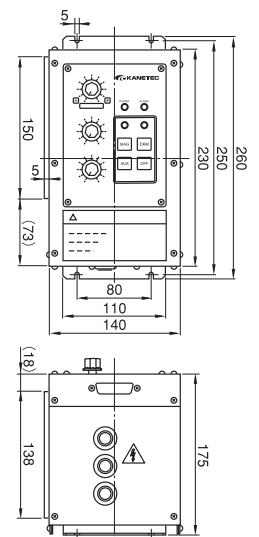

[mm (in)]

Model	Power Source	Output		Dimensions			Mass	
		Voltage	Current	Width	Height	Depth	Chuck Master	Operation Box
EPH-LW205A	Single-phase 200 VAC 50/60Hz	Permanent electromagnetic: 0—180 VDC (2sec) Low magnetic force: ±0—60 VDC (continuous)	5A	140 (+ 5) 5.51 (+0.19)	230 (9.05)	175 (6.89)	Approx. 4.7kg/10.3 lb	Operated from main unit panel.
140 (+30) 5.51 (+1.18)				Approx. 4.5kg/ 9.9 lb				
EPH-LW210A		10A	220 (+30) 8.66 (+1.18)	250 (9.84)	Approx. 6.0kg/13.2 lb	Approx. 0.6kg/1.3 lb		

※Non-contact Chuck Masters (with low magnetic force control) of permanent electromagnetic chucks (180 VDC version).
※The low magnetic force control is possible when used in combination with the permanent electromagnetic chuck Model EPT-D.
※Three types; rated output of 180 VDC-5A, 180 VDC-5A (with operation box) and 180 VDC-10A (with operation box) are available.

Model **EPTW** MICROPITCH TYPE

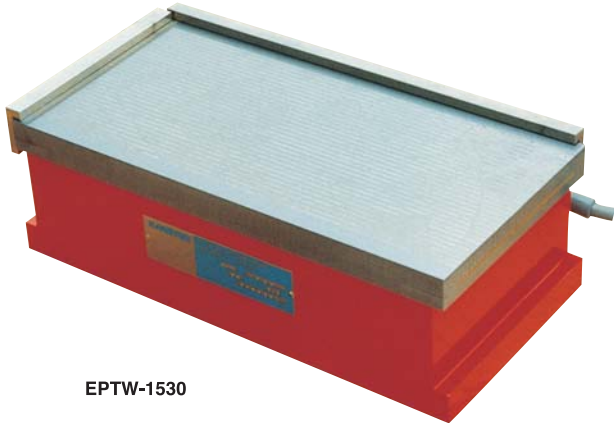

EPTW-1530

[Application]

Suitable for precision grinding on grinders and for holding thin and thick workpieces having a large area.

[Features]

- Thanks to finer pole pitches on the chuck work face, these chucks hold thin and wide workpieces firmly.
- Electricity is applied momentarily only to control the magnetomotive force when mounting and dismounting workpieces, minimizing heat generated internally to maintain accuracy.
- Electricity needs not be applied continuously even when holding workpieces, helping reduce running costs.
- The holding power is maintained in the event of power failure or cable breakage, thus improving safety.

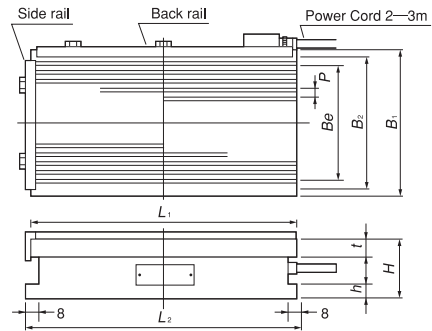

[mm (in.)]

Chuck controller required additionally



Model	Nominal Dimensions	Top Plate				Pole Pitch P	Bottom Plate			Height H	Voltage	Power Cord	Mass	Electro Chuck Master
		B_1	L_1	t	B_e		B_2	L_2	h					
EPTW-1530	150 (5.90) × 300 (11.8)	150 (5.90)	300 (11.8)	20	125 (4.92)	4 (0.8+3.2) 0.15 (0.03+0.12)	148 (5.82)	300 (11.8)	18	95 (3.74)	90 VDC	2m (78.7)	29kg/ 63 lb	EPS-215B
EPTW-1545	150 (5.90) × 450 (17.7)		450 (17.7)	(0.78)			148 (5.82)	450 (17.7)	(0.70)					
EPTW-2040	200 (7.87) × 400 (15.7)	200 (7.87)	400 (15.7)	25 (0.98)	173 (6.81)	198 (7.79)	400 (15.7)	20	120 (4.72)	3m (118)	65kg/143 lb			
EPTW-2050	200 (7.87) × 500 (19.6)		500 (19.6)				217 (8.54)					500 (19.6)	20	
EPTW-2560	250 (9.84) × 600 (23.6)	250 (9.84)	600 (23.6)	269 (10.5)	248 (9.76)	600 (23.6)	123kg/271 lb							
EPTW-3060	300 (11.8) × 600 (23.6)	300 (11.8)	600 (23.6)	269 (10.5)	298 (11.7)	600 (23.6)	147kg/324 lb							

※The chuck controller and clamp parts are not included. The KANETEC chucks work best when a KANETEC chuck controller is used.

※Turning the permanent electromagnetic chucks on and off must be limited to once per several minutes. If on/off operations are repeated frequently, the chucks may be damaged by overheat.

Model **EPZ-U** ROTARY TYPE



EPZ-1030UA

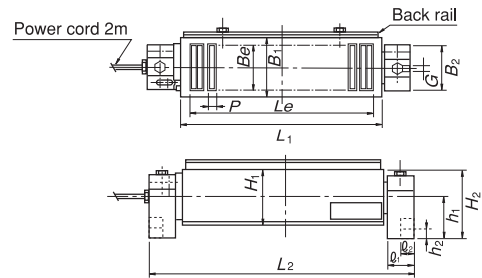

[mm (in.)]

Chuck controller required additionally



Model	Nominal Dimensions	Top Plate					Pole Pitch P	Rotary Stand					Length L_2	Height H_2	Voltage	Mass	Electro Chuck Master
		B_1	L_1	B_e	L_e	H_1		B_2	\varnothing_1	\varnothing_2	G	h_1					
EPZ-1025UA	100 (3.93) × 250 (9.84)	100 (3.93)	250 (9.84)	78 (3.07)	211 (8.30)	100	11 (2+9) 0.43 (0.07+0.35)	100	50	29	14	80	368 (14.4)	130 (5.11)	90 VDC	22kg/ 48 lb	EPS-215B
EPZ-1030UA	100 (3.93) × 300 (11.8)		255 (10.0)	96 (3.78)	255 (10.0)							80					
EPZ-1230UA	120 (4.72) × 300 (11.8)	120 (4.72)	300 (11.8)	96 (3.78)	240 (9.44)	(3.93)	14 (2+12) 0.55 (0.07+0.47)	(3.93)	(1.96)	(1.14)	(0.55)	95	418 (16.4)	30kg/ 66 lb			
EPZ-1530UA	150 (5.90) × 300 (11.8)	150 (5.90)	120 (4.72)	408 (16.0)	408 (16.0)	95 (3.74)	568 (22.3)	568 (22.3)	568 (22.3)	568 (22.3)	568 (22.3)	145	58	145	37kg/ 81 lb		
EPZ-1545UA	150 (5.90) × 450 (17.7)		450 (17.7)									120 (4.72)				408 (16.0)	

※The chuck controller and clamp parts are not included. The KANETEC chucks work best when a KANETEC chuck controller is used.

※Turning the permanent electromagnetic chucks on and off must be limited to once per several minutes. If on/off operations are repeated frequently, the chucks may be damaged by overheat.

ELECTROMAGNETIC CHUCKS
CHUCK CONTROLLERS
PERMANENT MAGNETIC CHUCKS
ELECTROMAGNETIC CHUCKS
BLOCKS FOR MC
VACUUM CHUCKS
PROMELTA SYSTEM
SINE BAR CHUCKS
INJECTION MOLDING MACHINE MOLD FIXTURE
WORKING TOOLS
MAGNETIC BLOCKS
MEASURING TOOL HOLDERS
MEASURING TOOLS

Model **EPS** EP CHUCK MASTER*

Power source for permanent electromagnetic chucks



[Application]

Rectifies an input from the AC power source to DC and momentarily outputs exciting current to permanent electromagnetic chucks. The automatic demagnetization circuit is activated to reduce residual magnetism in permanent electromagnetic chucks.

[Features]

- This chuck master is designed for use with electro permanent models : EPT-C, EPTW, EPZ, and EPZ-U.
- Microcomputer control ensures effective automatic demagnetization.
- Adjustable holding power.

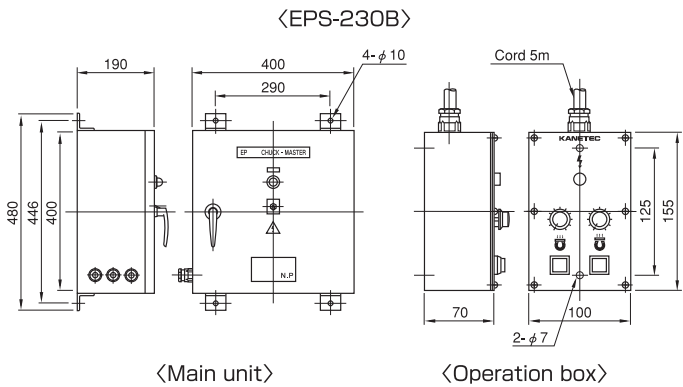

General models

[mm (in)]

Model	Power Source	Output		Dimensions			Mounting			Mass	Operating box			
		Voltage	Current	Width	Depth	Height	Width	Height	Hole		Width	Depth	Height	Cord
EPS-215B	Single-phase 200 VAC (50/60Hz)	20— 90 VDC	15A	180 (7.08)	130 (5.11)	250 (9.84)	120 (4.72)	275 (10.8)	4-φ 7 (0.27)	4.7kg/10.3 lb	—	—	—	—
EPS-230B			30A	400 (15.7)	190 (7.48)	400 (15.7)	290 (11.4)	446 (17.5)	4-φ10 (0.39)	18.3kg/40.3 lb	100 (3.93)	70 (2.75)	155 (6.10)	5m (196)
EPS-W215B		40—180 VDC	15A	180 (7.08)	130 (5.11)	250 (9.84)	120 (4.72)	275 (10.8)	4-φ 7 (0.27)	4.7kg/10.3 lb	—	—	—	—
EPS-W230B			30A	400 (15.7)	190 (7.48)	400 (15.7)	290 (11.4)	446 (17.5)	4-φ10 (0.39)	18.3kg/40.3 lb	100 (3.93)	70 (2.75)	155 (6.10)	5m (196)

*The applicable models are limited to EPT, EPTW and EPZ-U.

*EPS-230B is used as a power source unit for two or more units of the same model connected in series or specially ordered large chucks.

ELECTROMAGNETIC CHUCK CONTROLLERS
 PERMANENT MAGNETIC CHUCKS
 PERMANENT ELECTROMAGNETIC CHUCKS
 BLOCKS FOR MC
 VACUUM CHUCKS
 PROMELTA SYSTEM
 SINE BAR CHUCKS
 INJECTION MOLDING MACHINE MOLD FIXTURE
 WORKING TOOLS
 MAGNETIC BLOCKS
 MEASURING TOOL HOLDERS
 MEASURING TOOLS