

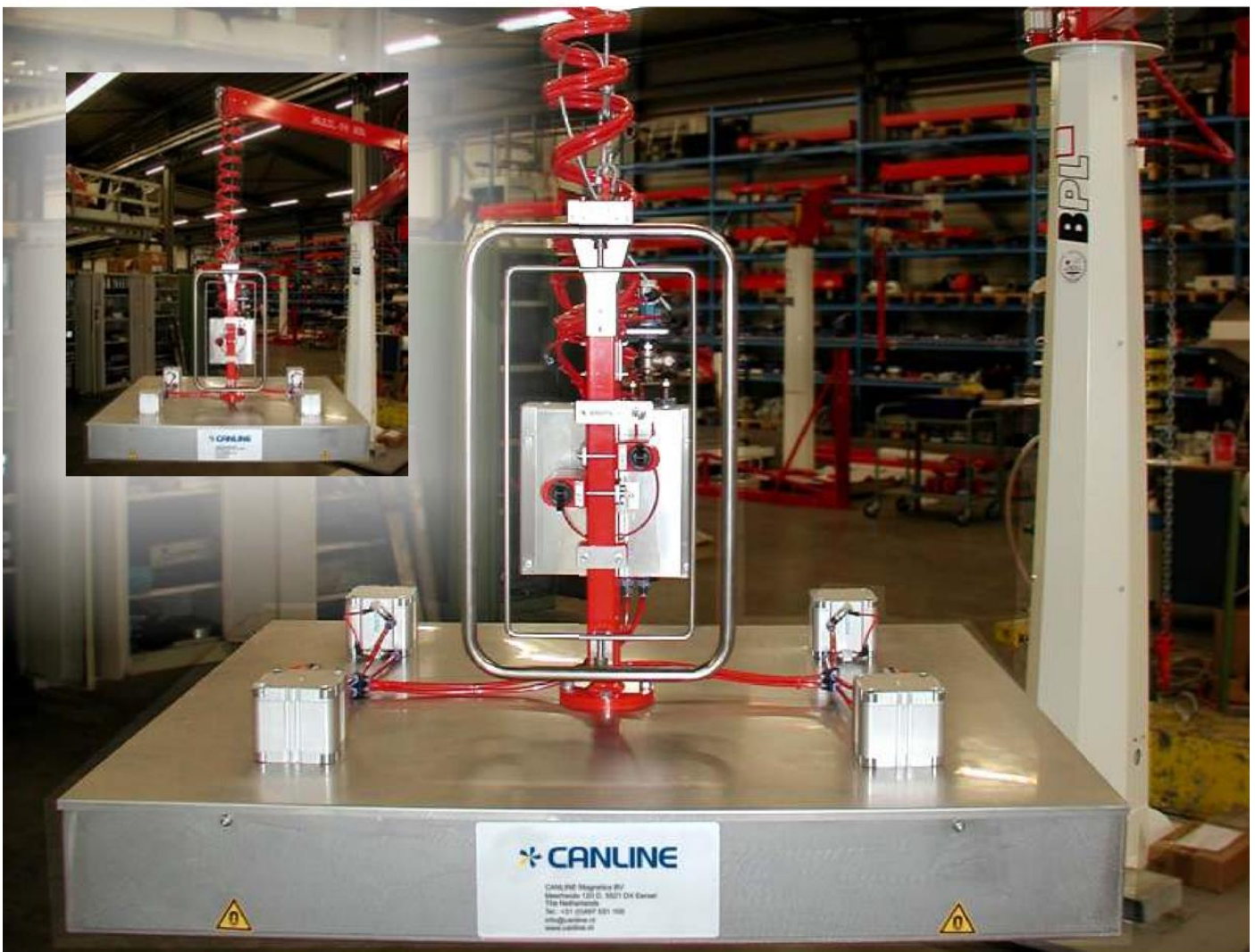

Canline Magnetic Manipulator



Handling your cans to weightless palletize/depalletize

The balancer can make a turn of 360 degrees. This makes it possible to move the load quickly and easily within an area of about 12 m².

Advantages include:

- Easy handling for every operator.
- Your employees will be well-motivated.
- The balancing system is protected in such a way, that accidents will be avoided.
- As the manipulator and the palletising agent work by means of compressed air, which is dry and clean, technical troubles are minimized.
- The load weight is continuously adjustable.
- The balancer can make a turn of 360 degrees. This makes it possible to move the load quickly and easily within an area of 12 M².
- The system will be supplied including a CE certificate and manual.

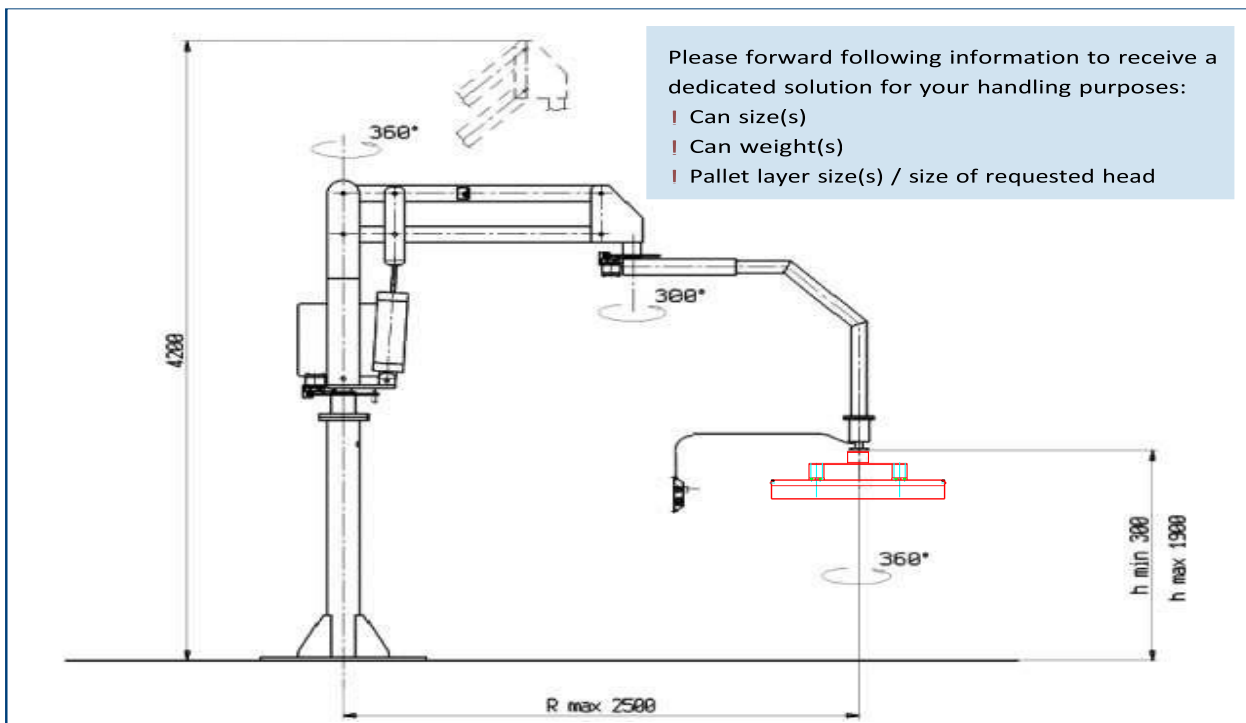

We firmly believe that product support is as important as product quality.

Contact us for more information on this product and product range Tel: **01525 372714** Email: **Sales@LHS.uk.com** Web: **<http://www.LHS.uk.com>**